

## User Manual

### mME DTZ541 Three-phase Electricity Meter LoRaWAN + LoRa

(Concept)

**Holley Technologie GmbH**

Angerburger Allee 43  
14055 Berlin

E-Mail: [info@holleytech.de](mailto:info@holleytech.de)  
<http://www.holleytech.de>

# Contents

1 Notice.....	1
2 Preface.....	2
3 General.....	4
3.1 Device versions.....	4
3.2 Housing element .....	5
3.3 Nameplate.....	6
4 Technical Data.....	7
4.1 Test-LED .....	8
4.2 Notes on measurement accuracy.....	8
5 Assembly.....	9
5.1 Attachment and connection .....	9
5.2 Rates control .....	9
5.3 Terminal block.....	10
6 LC-Display.....	12
6.1 LCD- Segments.....	12
6.2 Display of operation.....	13
7 PIN.....	15
7.1 INFO PIN .....	15
7.2 MSB PIN .....	16
7.3 LMN PIN.....	17
8 Tariff control .....	18
8.1 Configuration of the dual tariff function .....	18
8.2 LMN command for tariff switching .....	18
9 Operation of the counter with the key.....	20
10 LoRaWAN Function.....	27
10.1 Meter Reading Message (MRM).....	27
10.1.1 Meter Reading Message Header (MRMHDR) is defined as:.....	27
10.1.2 HEX-Code conversion.....	28

10.2 Meter Control Message (MCM).....29

    10.2.1 Meter Control Message (MCMHDR) defined as: .....30

    10.2.2 Unconfirmed Interval.....30

    10.2.3 Confirmed Interval .....31

    10.2.4 Max Wiederholungen .....31

    10.2.5 Example .....31

11 LoRa Function.....32

# 1 Notice

## Safety Instructions

The installation, installation and uninstallation of the meter may only be carried out by a certified electrician. For your own safety and to avoid damage to the device, please observe the following safety information. The information in the manual is important for your own safety in order to avoid damage. Please also comply with the generally applicable local safety regulations for electrical installations



### **Danger!**

Improper handling of live parts can lead to life-threatening injuries and accidents. Before starting the installation, the power must be switched off for the main circuit breaker. Incorrect labeling of fuses or circuit breakers can lead to the inadvertent shutdown of the wrong system. This would mean that the system being worked on would continue to be live. A suitable measuring device is used to check that there is no voltage.

## Guarantee Notice

Damage to the meter may only be repaired by the manufacturer. The meter may not be repaired yourself if it is damaged. Claims under the guarantee can only be asserted if the prerequisite is that the meter is not opened and / or the seal is undamaged. All guarantee and warranty rights expire when the device is opened. The same applies to damage caused by external influences

The meter is maintenance-free.

## Disclaimer

This description was created to the best of our knowledge and belief. The data in this manual are checked regularly and necessary corrections are included in the subsequent revisions.

## 2 Preface

LoRaWAN mME DTZ541, it is a new innovative product that was developed for the German market. The meter has 2 communication channels "LoRaWAN" and "LoRa". With the LoRaWAN network, the meter can regularly send the defined measurement data to the server. In addition, the user can use a LoRa adapter to query all measurement data from the meter at any time and also set all parameters.

As the "modern measuring device", the meter meets all legal requirements as well as standards and normative documents. The main ones are listed in the following table:

Norm	Explanation
IEC 62052-11	AC electricity meters - General requirements, tests and test conditions - Part 11: Measuring devices
IEC 62053-21	AC Electricity Meter - Special Requirements. Part 21: Electronic active consumption meters of accuracy classes 1 and 2
IEC 62056-21	Electricity metering - Data exchange for meter reading, tariff and load control - Part 21: Direct local data exchange
SML 1.04	SML – Smart Message Language
EN 50470-1	AC electricity meter; General requirements, tests and test conditions - measuring equipment (accuracy classes A, B and C); German version EN50470-1: 2006 Correction to DIN 50470-1 (VDE 0418-0-1): 2007-05
EN 50470-3	ALTERNating current electricity meter; Special requirements - Electronic power consumption counters (accuracy classes A, B and C); German version EN 50470-3:2006
DIN 43857-2	Electricity meter in insulating housing for direct connection up to 60 A limit current Main dimensions for three-phase meters
EN 60999-1	Connection material - Electric copper conductors; Safety requirements for screw terminals and screwless terminal points - Part 1: General requirements and special requirements for terminal points for conductors from 0.2 mm <sup>2</sup> up to and including 35 mm <sup>2</sup>
Richtlinie 2014/32/EU	DIRECTIVE 2014/32 / EU OF THE EUROPEAN PARLIAMENT AND OF THE COUNCIL of February 26, 2014 on the harmonization of the laws of the member states regarding the making available of measuring instruments on the market
Lastenheft Funktionale Merkmale	VDE / FNN instructions, specifications for basic meter functional features, version 1.3 (11/2016)

Lastenheft EDL	VDE / FNN specifications EDL electronic household meters, functional features and protocol, version 1.2 (11/2016)
-------------------	---

## 3 General

### 3.1 Device versions

This chapter lists options for the DTZ541 type electricity meter. These options then map a complete type designation of the meter. The individual meter can be defined by specific, clear characteristics such as maximum electricity, the tariff or the data interface. With the additional type number you can fully define the version of the DTZ541 three-phase energy meter.

**DTZ541 - \* \* \* \***  
**1            2 3 4 5**

Nr.	Norm	Explanation
1	Three-phase electricity meter	DTZ541: Design
2	Current direction	B: Reference counter with backstop L: Delivery counter with backstop Z: Bidirectional counter S: Delivery counter, balancing without backstop
3	Rates	D: Double rates E: Single rate
4	MSB- PIN	B: RS485 C: RS232
5	Accuracy	A: class A B: class B L: LoRaWAN + class A

The type of current direction is permanently configured as the factory setting and may no longer be changed during use. The double tariff function can be set in the same way as other functions specified in the FNN specification sheet for basic meters. The measuring device user can activate or deactivate via the LMN interface with the communication adapter "BAB-01".

### 3.2 Housing element

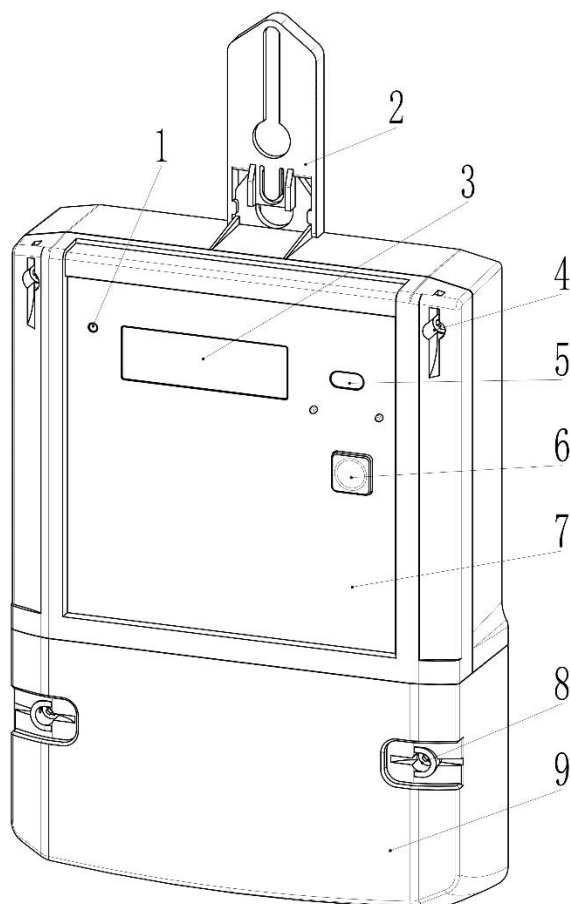

Nr.	Explanation	Nr.	Explanation
1	LED Pulse output	6	Control button for switching the display and entering the PIN
2	Optional extension of the upper attachment	7	Sealable housing cover
3	Two-line display	8	User security can be secured with a wire seal
4	Housing cover protection under calibration law	9	Terminal cover
5	INFO customer PIN		



### 3.3 Nameplate

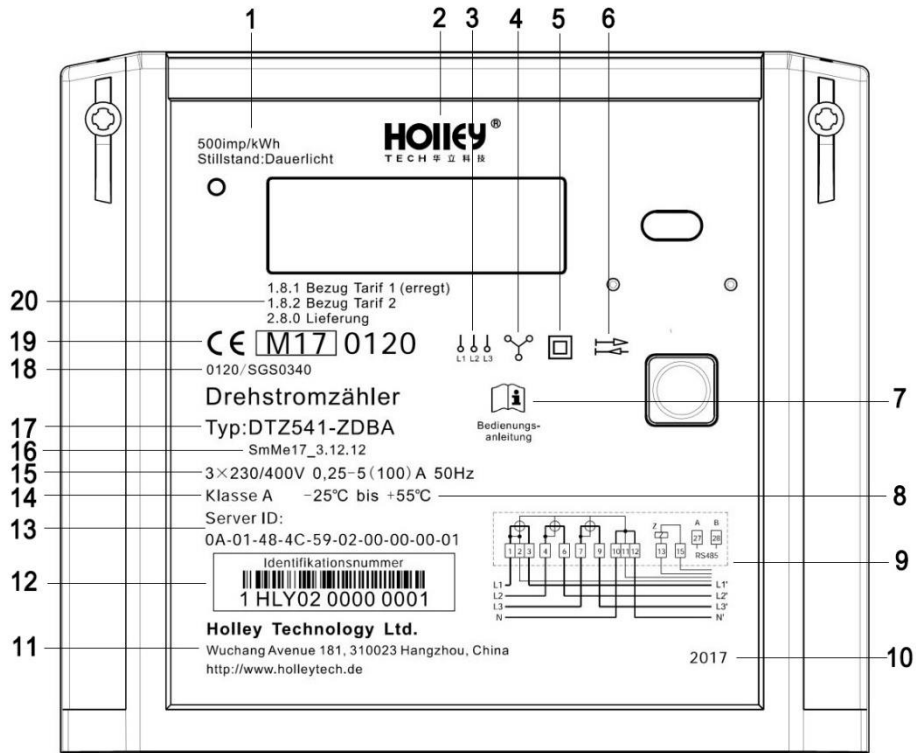

Nr.	Explanation	Nr.	Explanation
1	LED- Pulse constant	2	Logo from manufacturer
3	AC electricity meter	4	Three-phase four-wire meter
5	Protection class III	6	Information on the type of measurement
7	operation manual	8	Temperature range
9	Circuit diagram	10	Construction year
11	Manufacturer's address	12	Unique identification number according to DIN 43863-5
13	Server ID	14	Measurement accuracy
15	Connection conditions	16	Material number by the customer
17	Design	18	Number of the EC-type examination certificate
19	CE- Conformity mark	20	OBIS Code and register

## 4 Technical Data

Features	Explanation
Connection type	Dreiphasen-Vierleiter / Einphasen-Wechselstrom
frequency	50Hz
Rated voltage	3 * 230/400 V 1*230V auf L1, L2, L3
Current $I_{min}$ - $I_b$ ( $I_{max}$ )	0,25-5(100) A or 0,25-5(60) A
Starting current	$0.004 \cdot I_b = 0,02$ A
Transient current ( $I_{tr}$ )	$10\% \cdot I_b = 0,5$ A
Surge voltage resistance	6 kV, IEC 62052-11
Short-circuit strength	$30I_{max}$ , IEC 62053-21
Power consumption	Current path: <0,2VA Voltage path: <0,5W
Measurement accuracy	Class A (EN50470-1-3) or Class2.0 (IEC62053-21)
LED pulse output	500 or 5 000 or 10 000 Imp/kWh
Metrology	Current direction +A: (Single rate) only 1.8.0; (Double rate) Change between 1.8.1 and 1.8.2 Current direction- A: 2.8.0 (Double rate) Substitution between 2.8.1 and 2.8.2
External rates switching control (with double rate meters)	Clamp 13 u. 15
LC-Display	Format: Two lines Viewing angle: 15° (from above) and 60° (from left, right, down) Digit dimensions in the range of values: 3,5mm * 8mm (min.) Digit dimensions in the code area: 1,9mm * 4,2mm (min.)

Features	Explanation
<b>Mechanical environmental conditions</b>	M1
<b>Electromagnetic environmental conditions</b>	E2
<b>Protection class</b>	IP51
<b>Relative humidity</b>	95% non-condensing, <75% annual mean according to IEC 62052-11, EN 50470-1 and IEC 60068-2-30
<b>Temperature range</b>	-25 ° C ... + 55 ° C (operation) -40 ° C ... + 70 ° C (storage)
<b>lifespan</b>	20 years
<b>User protection</b>	2 security options for seal
<b>Terminal block</b>	DIN 43857 part 2
<b>Clamps Ø</b>	9,5mm
<b>casing material</b>	Glass fiber reinforced polycarbonate
<b>Size</b>	290,5 mm (L) * 170 mm (W) * 52,5 mm (H)
<b>Weight</b>	720g

## 4.1 Test-LED

The test LED of the DTZ541 illuminates the infrared light. It is used to output energy-proportional active energy pulses and to display start-up and idling. When idling, the test LED lights up continuously. If the meter measures above its start-up threshold, the energy-proportional pulses are displayed. The accuracy of the DTZ541 is determined by the LED pulse outputs.

## 4.2 Notes on measurement accuracy

Only the specified meter types with the associated software version numbers are permitted for use of the LMN interface in accordance with calibration law. For this purpose, the respective approved software versions must be observed. The measured value data have a resolution of 4 decimal places. All parties involved must ensure that the requirements from PTB-A 50.8, Appendix A3 for latency times and applicable tariff application cases are complied with, also taking into account several communication adapters connected to a smart meter gateway.

# 5 Assembly

## 5.1 Attachment and connection

Before installing and commissioning the meter, check whether the meter is damaged. please check whether the meter is damaged. If you detect any damage to the housing or a missing legal metrological fuse, the meter must not be used if the seals are missing or the housing is damaged. The DTZ541 three-phase energy meter is suitable for mounting on a meter position in accordance with DIN VDE 0603-2-1, three-point attachment DIN 43857-2 and should be connected according to the circuit diagram.

### Dimension

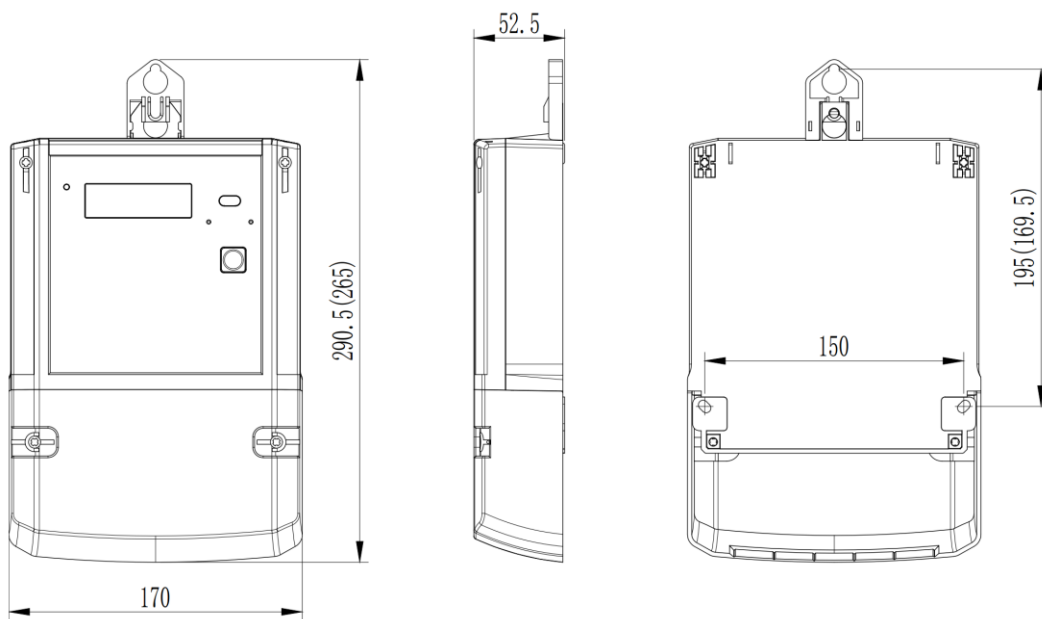

Double rates(DIN 43856 Schltg.: 4101MME)

Single rates(DIN 43856 Schltg.: 4000MME)

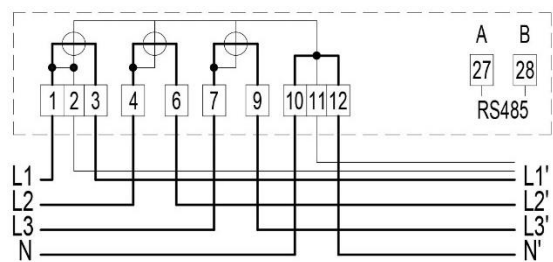
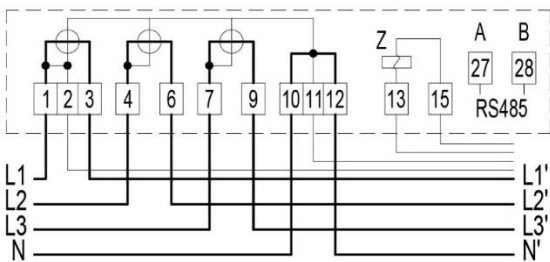

## 5.2 Rates control

The rates control is carried out regulated by potential-free rates control terminals 13 and 15. With the double rates meter, the rates can be switched by activating the terminals with system voltage by a rates control device. Without control, rates 2 is active. rate T1 is activated when voltage is applied to terminal 13.

### 5.3 Terminal block

In order to ensure a secure electrical connection between connecting cables and terminals, the clamping screws must be tightened with a corresponding torque in accordance with DIN EN 60999-1. Tighten the terminal screws with a corresponding torque in accordance with DIN EN 60999-1 to ensure a safe electrical connection between the connecting cables and to ensure the terminals. The meter has tinned copper shunts and can be contacted directly on copper or aluminum lines. The suitability of the meter for connection is indicated on the meter.

#### Variant 60A (cage terminal block)

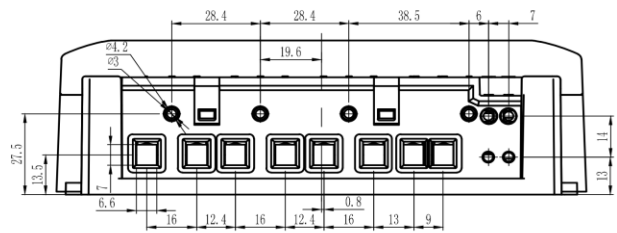
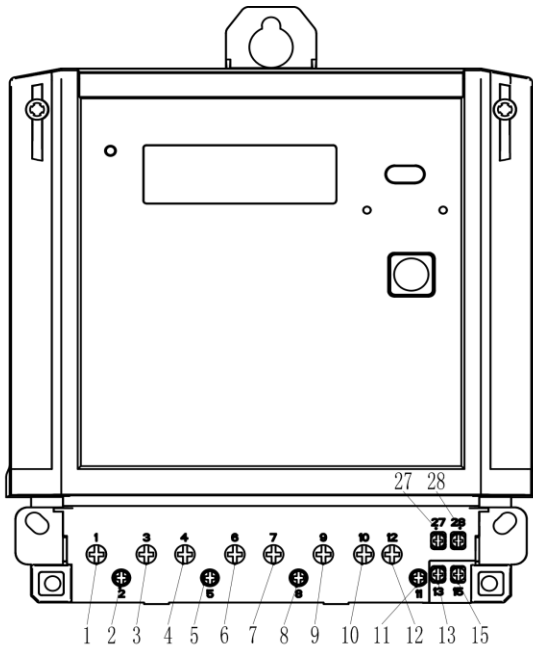

#### Variant 100A

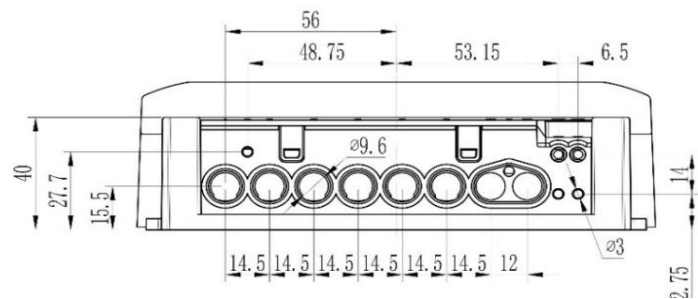
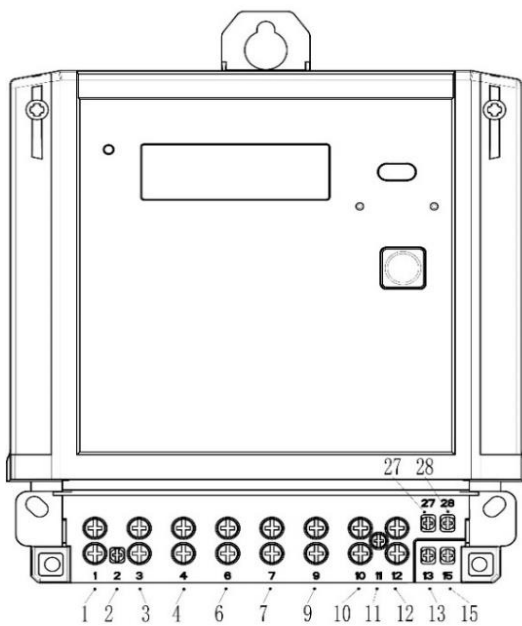

<b>Variant 60A/100A</b>	<b>Phase Clamps 1, 3, 4, 6, 7, 9, 10, 12</b>	<b>Voltage / N tap 2, 11</b>	<b>Additive - Clamps 13, 15, 27, 28</b>
<b>Clamps Ø (mm)</b>	<b>9,5</b>	<b>3,0</b>	<b>3,0</b>
<b>Min. Connection cross-sections (mm<sup>2</sup>)</b>	<b>6</b>	<b>1,5</b>	<b>1,5</b>
<b>Max. Connection cross-sections (mm<sup>2</sup>)</b>	<b>35</b>	<b>2,5</b>	<b>2,5</b>
<b>Prescribed tightening torque (Nm)</b>	<b>1,5...2,5</b>	<b>0,5</b>	<b>0,5</b>
<b>Kopf</b>	<b>PZ2</b>	<b>Kreuzschlitz</b>	<b>Kreuzschlitz</b>
<b>Thread size</b>	<b>M6</b>	<b>M3</b>	<b>M3</b>

# 6 LC-Display

## 6.1 LCD- Segments

The meter has an LC display with additional symbols to identify measured values and working conditions.

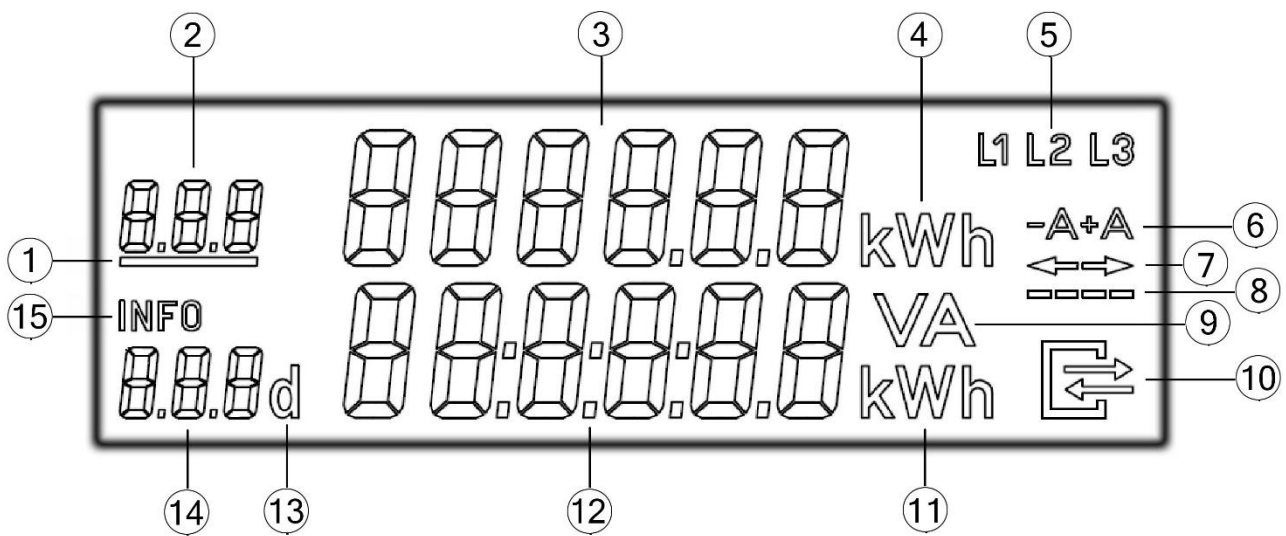

Nr.	Explanation
1	Active tariff display
2	OBIS code of the labor value
3	Display of meter reading
4	Unit for meter reading
5	Phase control
6	Energy direction
7	Direction of flow of the measured energy
8	simulates carrier
9	Unit for voltage, current or apparent power
10	Symbol for communication via the electrical data interface
11	Unit for performance or historical values

12	Display of current performance or info
13	Abbreviation of "Day" for historical values
14	Information content icon
15	Info display icon

## 6.2 Display of operation

The display test for 15 seconds when the voltage is restored. Upper display line segments and lower display line segments alternately fade in and out 3 times.

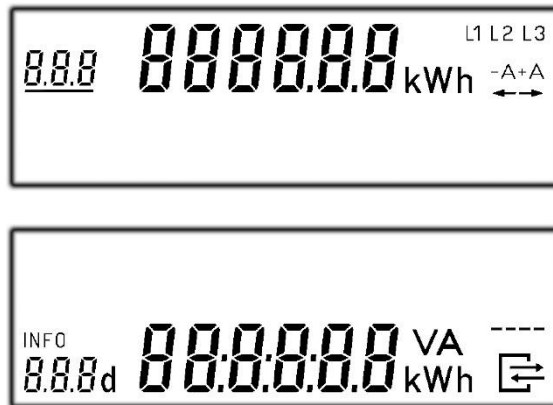

The software version number of the metrological part is shown on the display with the associated checksum. The software version is indicated with index 1.



If a communication adapter "BAB-01" is connected, the display then shows its software version number and the associated checksum. The software version is indicated with index 2.



Rolling display of billing-relevant values. The display of the instantaneous power in the second line must be enabled by entering a PIN:



Variant of single tariff for current direction + A: only register 1.8.0



Double tariff variant for current direction + A: alternating display between registers 1.8.1 and 1.8.2

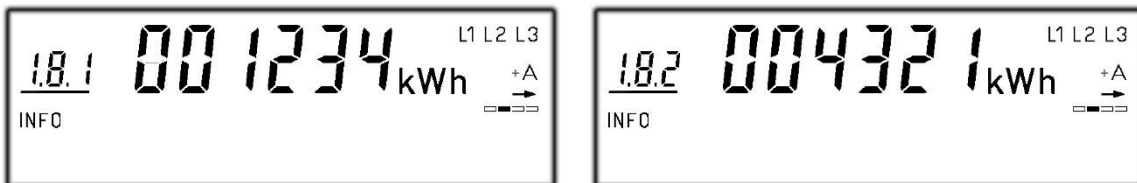

Variant of individual tariff for current direction -A: only register 2.8.0



Double tariff variant for current direction -A: alternating display between registers 2.8.1 and 2.8.2

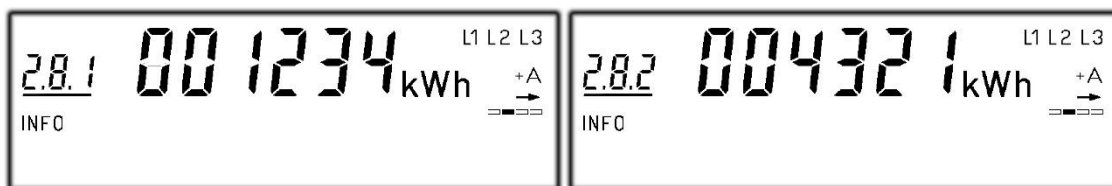

The 6 register values 1.8.0, 1.8.1, 1.8.2, 2.8.0, 2.8.1 and 2.8.2 are relevant for billing. They are always shown in the same way as the variant in the first line of the display and only kWh without decimal places.

After entering the PIN, all the values shown in the second line are for customer information only and may not be used for billing-related purposes. This applies in particular to the instantaneous power, the historical consumption values (1d, 7d, 30d, 365d), as well as consumption values since zero setting.

If an error is detected which means that the measured values can no longer be used for accounting, the display shows this message for 2 seconds after each partial step of the information to be displayed on a rolling basis.



# 7 PIN

## 7.1 INFO PIN

An optical data interface on the front is available for the end user. Its constant data rate is 9600 baud and the character encoding is 8-N-1. The transmission protocol is according to SML specification version 1.04. The interfaces work in "PUSH" mode and send out one data record every second. The data has 3 variants. If you do not enter a PIN for the "INFO OFF" setting, it is the "Reduced data record", otherwise it is the "Complete data record". The "manufacturer-specific data record" can also be activated or deactivated via the rear interface.

### Record to the INFO-PIN

Reduced data set	Complete data set	Manufacturer-specific data record
<ul style="list-style-type: none"> <li>• Manufacturer ID</li> <li>• Device identification</li> <li>• Meter reading + A, tariff-free (without decimal places, only for single-tariff meters)</li> <li>• Meter reading + A, tariff 1 (without decimal places, only for two-tariff meters)</li> <li>• Meter reading + A, tariff 2 (without decimal places, only for two-tariff meters)</li> <li>• Meter reading -A, tariff-free (without decimal places, only for single-tariff meters)</li> <li>• Meter reading -A, tariff 1 (without decimal places, only for two-tariff meters)</li> <li>• Meter reading -A, tariff 2 (without decimal places, only for two-tariff meters)</li> </ul>	<ul style="list-style-type: none"> <li>• Manufacturer ID</li> <li>• DeviceIdentification</li> <li>• Meter reading + A, tariff-free (only with one-tariff meter)</li> <li>• Meter reading + A, tariff 1 (only for two-tariff meters)</li> <li>• Meter reading + A, tariff 2 (only for two-tariff meters)</li> <li>• Meter reading -A, tariff-free (only with single-tariff meters)</li> <li>• Meter reading -A, tariff 1 (only for two-tariff meters)</li> <li>• Meter reading -A, tariff 2 (only for two-tariff meters)</li> <li>• Current total active power with sign</li> </ul>	<ul style="list-style-type: none"> <li>• Manufacturer ID</li> <li>• Device identification</li> <li>• Meter reading + A, tariff-free (only with one-tariff meter)</li> <li>• Meter reading + A, tariff 1 (only for two-tariff meters)</li> <li>• Meter reading + A, tariff 2 (only for two-tariff meters)</li> <li>• Meter reading -A, tariff-free (only for single-tariff meters)</li> <li>• Meter reading -A, tariff 1 (only for two-tariff meters)</li> <li>• Meter reading -A, tariff 2 (only for two-tariff meters)</li> <li>• Current total active power with sign</li> <li>• Active power L1</li> <li>• Active power L2</li> <li>• Active power L3</li> <li>• Voltage L1</li> <li>• Voltage L2</li> </ul>

<ul style="list-style-type: none"><li>• Firmware version</li><li>• Firmware checksum</li><li>• Error register</li></ul>		<ul style="list-style-type: none"><li>• Voltage L3</li><li>• Current L1</li><li>• Current L2</li><li>• Current L3</li><li>• Phase angle U-L2 to U-L1</li><li>• Phase angle U-L3 to U-L1</li><li>• Phase angle I-L1 to U-L1</li><li>• Phase angle I-L2 to U-L2</li><li>• Phase angle I-L3 to U-L3</li><li>• frequency</li><li>• Historical consumption value "1d" without previous values</li><li>• Historical consumption value "7d" without previous values</li><li>• Historical consumption value "30d" without previous values</li><li>• Historical consumption value "365d" without previous values</li><li>• Historical consumption value since the last reset</li><li>• Firmware version</li><li>• Firmware checksum</li><li>• Error register</li></ul>
---	--	---

## 7.2 MSB PIN

DTZ541 has an MSB interface from terminals 27 and 28. Its constant data rate is 9600 baud and the character coding is 8-N-1. The transmission protocol is RS485 according to SML specification version 1.04. The interfaces work in "PUSH" mode and send out a manufacturer-specific data record every second.

## **7.3 LMN PIN**

The MSB interface can be expanded as the LMN interface with the Holley communication adapter BAB-01. Its constant data rate is 1Mbit and the character encoding is 8-N-1. The LMN interface meets the requirements of the FNN specification sheet for basic meters, the PTB requirements for communication adapters PTB-A50.8 and the requirements of BSI TR03109. This LMN interface can communicate directly with SMGw.

## 8 Tariff control

For the DTZ541 with double tariff function, the tariffs may be activated and controlled via terminals 13 and 15 or via the LMN interface. Control via the LMN interface has priority over the control signal supplied to the control terminals. If the activation via the LMN interface is recognized and there is no further activation for a period of more than 90s, the priority status is canceled again and activation via control terminals is used. If the DTZ541 is in the operating mode "Operation in a secure SMGW environment", the dual tariff function must be set to the "suppressed" state for all energy directions.

### 8.1 Configuration of the dual tariff function

Another register with data type "Unsigned8" and class "Data" must be included under the code numbers (01 00 5E 31 01 0D). This can be written as well as read. Writing automatically deactivates the dual tariff function. Writing with impermissible bit combinations must be answered with the attention "81 81 C7 C7 FE 05". The permitted bit coding and corresponding functions are described in the following table.

Task	Bit7 MS B	Bit6	Bit5	Bit4	Bit3	Bit2	Bit1	Bit0 LSB
DTF prepared in energy direction "1.8 ..."				1				
DTF "1.8 ..." suppressed in energy direction				0				
DTF prepared in energy direction "2.8 ..."					1			
DTF suppressed in energy direction "2.8 ..."					0			
Assignment "LMN tariff control ON" Or Register "... 8.1" is active							1	
Assignment "LMN tariff control ON" Or Register "... 8.2" is engaged							0	
reserved	0	0	0			0		0

### 8.2 LMN command for tariff switching

Another register with data type "Boolean" and class "Data" must be included under the code numbers (01 00 5E 31 01 0C). This can be written as well as read. Writing (TRUE or FALSE) automatically activates the dual tariff function. The letter is to be ignored (and answered with the attention "81 81 C7 C7 FE 05") if at least one double tariff function is not in the "prepared" state. If the double tariff

function is “prepared” and has been activated, the double tariff function remains in the “prepared and activated” state even after the operational readiness has been lost (loss of mains voltage) and can only be reset in accordance with Section 8.1.

## 9 Operation of the counter with the key

DTZ541 has a physical button and, optionally, an optical button in the position of the INFO interface. By entering a "short key press" and a "long key press (5s)" additional information is shown in the second line of the display. The corresponding functions can be set here. The different key commands are:

- short key press (<2s)
- repeated short keystrokes
- long press (>5s)

The following explanation describes the operating processes of a complete counter. Some steps are not possible with some meters due to different variants. For example, a reference meter does not have historical values of "-A".

When the historical values are displayed, the scrolling mode is interrupted in the first line and the corresponding OBIS code for the historical values is displayed. This enables the historical values to be clearly assigned to the respective type of energy.

Operating status from the display



Displaytest



PIN- input



Enter the 4 digit of the pin



If the PIN is correct, the display then shows the performance

If the PIN is not correct, the display shows the operating mode



historical value "+ A" since the last reset



historical value "-A" since the last reset



Setting of the deletion of the historical value "+ A" and "-A" since the last reset





historical daily value "+ A"

or  Activation of the delete function



delete historical value "+ A" and "-A" since the last reset



historical daily value "+ A"



historical weekly value "+ A" to call up 730 individual daily values "+ A"

Or

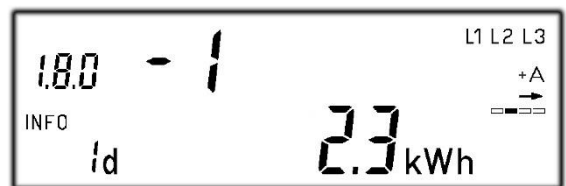

second historical daily value "+ A"



display all 730 daily values "+ A"

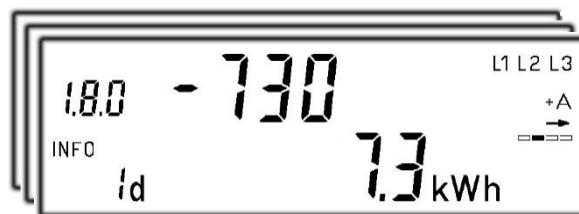

Deactivating the inspection of the daily value "+ A"



historical weekly value "+ A"



historical monthly value "+ A" or  104 historical weekly values "+ A" can be viewed



historical annual value "+ A" or  24 historical monthly values "+ A" can be viewed



historical daily value "-A" or  2 historical annual values "+ A" can be viewed



historical weekly value "-A"

Or  730 historical daily values "-A" can be viewed



second historical historical daily value "-A"

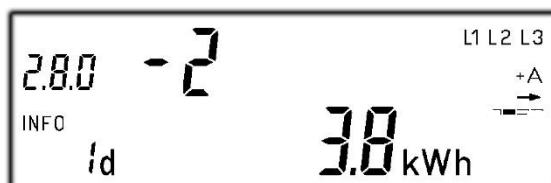

all 730 daily values "-A" can be viewed



Deactivating the inspection of the daily value "-A"



historical weekly value "-A"

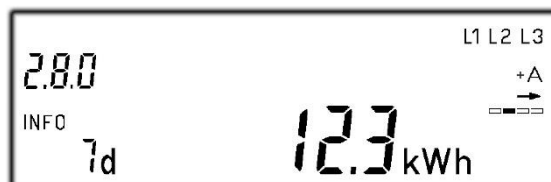

historical monthly value "-A" or   104 historical weekly values "-A" can be viewed



historical annual value "-A" or  24 historical monthly values "-A" can be viewed



Setting the deletion of historical values "+ A" and "-A"

or  2 historical annual values "-A" can be viewed



State of the INFO PIN

or  Activation of the delete function



historical value "+ A" and "-A" to be deleted



State of the INFO PIN



State of the PIN input

or  Activation of the setting of the INFO-PIN



Status of the PIN input



to stop displaying the additional information

or  to set the PIN entry as "off" in order to call up the additional information again



to stop displaying the additional information



to call up the additional information again

# 10 LoRaWAN Function

This chapter describes the payload from the Holley LoRaWAN electricity meter. There are two messages in the log, “Meter Reading Message” (MRM) is sent regularly by the meter and “Meter Control Messages” (MCM) is sent by the LoRaWAN server.

## 10.1 Meter Reading Message (MRM)

Size (Byte)	1	[0 ..30]
Part	MRMHDR	content

### 10.1.1 Meter Reading Message Header (MRMHDR) is defined as:

Bit#	7..6	5..1	0
part	execution	Identifier	State

#### Execution

execution Bits	description
00	LoRaWAN Meter Protocol V1
01..11	RFU

#### Identifier

Qualifier Bits	Counter types	description
00000	None (if only the status is send)	
00111	mME-DTZ541	Data record-1 from the mME counter
01000		Data record-2 from the mME counter
01001 ... 11111	RFU	



Explanation from the payload:

Consumption value \_1.8.0: "40.2381 kWh",

Consumption value \_1.8.1: "40.2381 kWh",

Consumption value \_1.8.2: "0 kWh",

Consumption value \_2.8.0: "0 kWh",

Consumption value \_2.8.1: "0 kWh",

Consumption value \_2.8.2: "0 kWh",

power \_P<sub>Sum</sub>: "9.7 W",

power \_P<sub>L1</sub>: "0 W",

power \_P<sub>L2</sub>: "9.7 W",

power \_P<sub>L3</sub>: "0 W",

Second index: 4733544,

Status word: "00080104",

- "S08\_ Measuring mechanism ": " Start-up ",
- "S09\_ Magnetic\_manipulation ": "No",
- "S10\_ Terminal cover\_Manipulation ": "NO",
- "S11\_ Energy direction ": "+A",
- "S12\_ Energy direction \_L1": "+A",
- "S13\_ Energy direction \_L2": "+A",
- "S14\_ Energy direction \_L3": "+A",
- "S15\_ Rotating field \_L1\_L2\_L3": "Ja",
- "S16\_ Backstop ": " inactive ",
- "S17\_ Error\_curification-relevant ": "No",
- "S18\_ voltage \_L1": " unavailable ",
- "S19\_ voltage \_L2": " available ",
- "S20\_ voltage \_L3": " unavailable "

## 10.2 Meter Control Message (MCM)

Size(Byte)	1	[4]	[4]	[1]
Part	MCMHDR	Unconfirmed interval	Interval confirmed	Max Retries



**10.2.1 Meter Control Message (MCMHDR) defined as:**

<b>Bit#</b>	<b>7</b>	<b>6</b>	<b>5</b>	<b>4</b>
Part	Version, Highbit	Version, LowBit	Send Readings	Send Now
<b>Bit#</b>	<b>3</b>	<b>2</b>	<b>1</b>	<b>0</b>
Part	RFU	RFU	RFU	RFU

**Execution**

<b>Version Bits</b>	<b>description</b>
00	LoRaWAN Meter Protocol V1
01..11	RFU

**Send Readings**

<b>Send Readings Bit</b>	<b>description</b>
0	Off, do not send any uplink packets at the defined intervals until the bit is set to 1 again. No messages (neither confirmed nor unconfirmed) will be sent. The meter just keeps listening to new commands.
1	On, send readings at the defined intervals

**Send Now (To a single read, regardless of the sending interval)**

<b>Send Now bit</b>	<b>description</b>
0	Off, no need to send an additional meter reading in response to this message.
1	On, regardless of the other parameters, the electricity meter as soon as the duty cycle allows reading. Even if the “Send Reading Bit” is 0.

**10.2.2 Unconfirmed Interval**

4 byte integer denotes the multiple of 1 minute long interval in which the meter readings are sent as an unconfirmed

message (no confirmation expected). The default value is "F" (every 15 minutes) and the minimum value is "5" (every 5 minutes).

If "Send Readings" is switched off, the meter readings still send the message, omitting only readings (that is, only the header with the status bits). The unacknowledged message will only send if no acknowledged message is scheduled at the same time.

If an unacknowledged message and an acknowledged message are sent at the same time, then no unacknowledged message is sent because both intervals end.

A value of "0" means: does not send unacknowledged messages. A value "FFFF FFFF" has the special meaning of: no current setting changes for interval unconfirmed.

The interval begins when the meter is connected (request 4) and again when a meter control message with a value other than "FFFF FFFF" for unacknowledged interval is received. The first message is sent at the beginning of the first interval.

### 10.2.3 Confirmed Interval

Der Standardwert ist 0 (einmal wöchentlich).

### 10.2.4 Max Wiederholungen

4-byte integer denotes the multiple of 15-minute intervals in which the meter readings are sent as a confirmed message (awaiting confirmation and retry if no confirmation is received). If "Send Readings" is switched off, the Meter Readings Message can still be sent, only with the omission of Reading.

1 byte integer specifies the maximum number of repetitions if no acknowledgment is received for a confirmed message. 0xFF means: no change. The default is 3.

### 10.2.5 Example

08000000050000000003: Change the interval of data record-2 as 5 minutes.

080000000F0000000003: Change the interval of data record-2 as 15 minutes.

07000000050000000003: Change the interval of data record-1 as 5 minutes.

## **11 LoRa Function**

With the Holley LoRa adapter and super password, all parameters of the LoRaWAN function can be configured and the meter data can be read at any time.