

Wireless 3-Phase Current Meter with 3 x 75A Clamp-On CT R718N37 Data Sheet

Wireless Sensor Network Based on LoRa Technology



Copyright©Netvox Technology Co., Ltd.

This document contains proprietary technical information which is the property of NETVOX Technology and is issued in strict confidential and shall not be disclosed to others parties in whole or in parts without written permission of NETVOX Technology.

The specifications are subjected to change without prior notice.

Introduction

The NETVOX wireless three-phase current detector is used to detect three-phase electrical input current. The device is compatible with the LoRaWAN protocol and integrates a chip module that conforms to the LoRaWAN wireless protocol to display the collected data in the gateway. The device is powered by battery and obtains the load AC current value through the current transformer. The device adopts the clamp-on current transformer, which can be conveniently connected to the measuring device.

Operating Principle

This device is connected to a current transformer. The current transformer is an instrument that converts the primary side large current into a secondary side small current according to the principle of electromagnetic induction, and the primary side large current is isolated from the secondary side small current, and the secondary side of the device is monitored. Low current, battery powered, to ensure safe use of the device.

Application

- Indoor current detecting devices for homes, hotels, office buildings, shopping malls, etc.
- Smart city
- Thermal system equipment

Wireless 3-Phase Current Meter with 3 x 75A Clamp-On CT

Main Characteristic

- Apply SX1276 wireless communication module
- 2 ER14505 battery AA SIZE (3.6V / section) in parallel power supply
- Protection level: host body IP53, sensor IP30
- The base is attached with a magnet that can be attached to a ferromagnetic material object
- Adopt clamp-on current transformer, it can easily connect to the device to be detected
- LoRaWAN™ Class A compatible
- Frequency Hopping Spread Spectrum (FHSS)
- Third-Party online wireless sensor monitoring and notification system to configure sensors, view data and set alerts via SMS text and email (optional)
- Available third-party platform: Actility/ThingPark, TTN, MyDevices/Cayenne
- Improved power management for longer battery life
- Battery Life*2:

Please refer to web: http://www.netvox.com.tw/electric/electric_calc.html

At this website, users can find battery lifetime for various models at different configurations.

*1. Actual range may vary depending on environment.

*2. Battery life is determined by sensor reporting frequency and other variables

Wireless 3-Phase Current Meter with 3 x 75A Clamp-On CT
Electric

Power Supply	2 ER14505 lithium batteries (3.6 V, 2400mAh / section) in parallel
Battery Life	Battery life are 5 years (condition: Ambient temperature 25 °C, report once every 30mins, txpower = 20dBm, LoRa spreading factor SF = 10)
Standby Current	25uA
Wakeup Current	7mA
RF Receiving Current	11 mA @ 3.3V
RF Emission Current	127 mA @ 3.3 V
Battery Measurement Accuracy	± 0.1V
Current Measurement Accuracy	<±1%
Current Resolution	1mA
Current Measurement Range	100mA to 75A (varies according to the configuration of the current transformer)
Current Measurement Accuracy	<±1% (300mA to 75A)

* Specific electrical characteristics may vary depending on the power supply voltage.

Clamp-on Current Transformer Parameter

Rated Primary Current	30A, 50Hz ~ 60Hz
Rated Secondary Current	10mA
Saturation Current	≥75A
Ratio	3000: 1
Load Resistance	10 Ω
Accuracy	1%
Electrical Strength	3000V
Housing Material	Flame Retardant Grade 94-V0 UL Material
Environmentally Friendly	ROHS compliant
Operating Temperature	-40 °C ~ 85 °C

Wireless 3-Phase Current Meter with 3 x 75A Clamp-On CT

Frequency

Frequency Range	863MHz-928MHz 470MHz-510MHz
Power Output	US915 20dbm AS923 16dbm AU915 20dbm CN470 19.15dbm EU868 16dbm KR920 14dbm IN865 20dbm
Receiving Sensitivity	-136dBm (LoRa, Spreading Factor = 12, Bit Rate = 293bps) -121 dBm (FSK, Frequency deviation = 5kHz, Bit Rate = 1.2kbps)
Antenna Type	Built-in antenna
Communication Distance	10 km (the actual transmission distance depends on the environment.)
Data Transfer Rate	0.3kbps ~ 50k bps
Modulation	LoRa / FSK (Note: you can choose one of them)
Available LoRaWAN Band	EU863-870, US902-928, AU915-928, KR920-923, AS923, CN470-510 (Note: optional, to be done in the factory configuration)

Physical

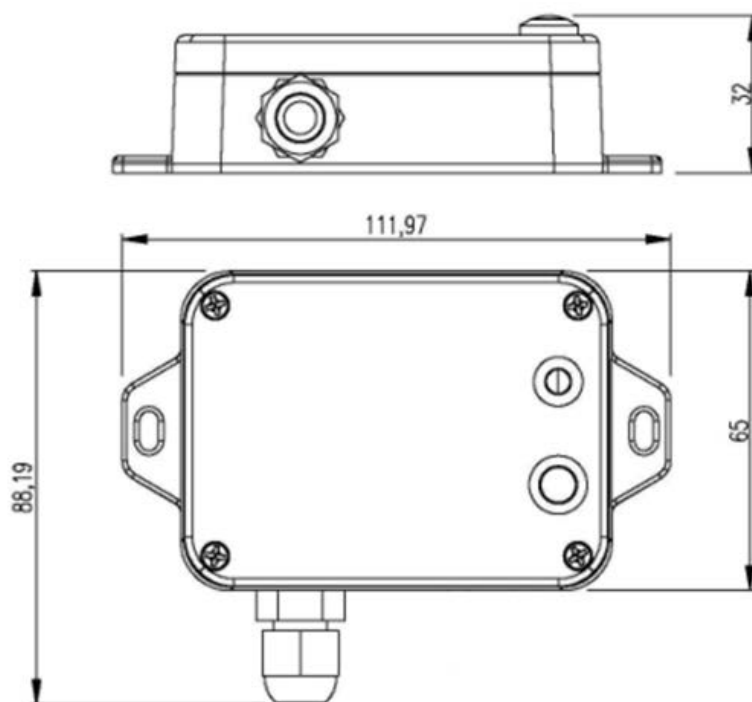

Wireless 3-Phase Current Meter with 3 x 75A Clamp-On CT

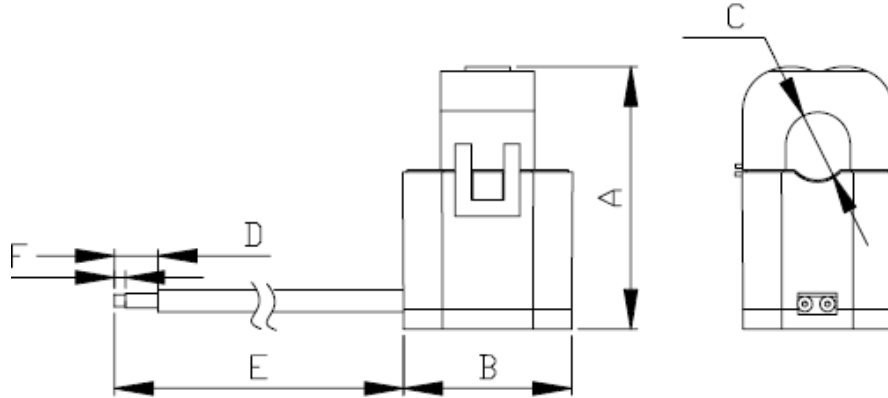

A	B	C	D	E	F
41max	27.5max	10±0.2	25±5	900±30	6±1

Dimension	Host body: L: 112 mm *W: 88.19 mm *H: 32 mm Sensor: H:42.5 *L:27.5 *W:25mm
Host body Weight	About 141 g
Sensor Weight	About 49.6*3g
Sensor External Wiring Length	About 900mm
Ambient Temperature Range	-20°C ~ 55°C
Storage Temperature Range	-40°C ~ 85°C
Ambient Humidity Range	<90% RH (No condensation)
Mounting	Screw / Magnet